

| Medida | U/E |
|--------|-----|
| 250 BL | 20 |
| 300 BL | 20 |
| 350 BL | 20 |
| 400 BL | 20 |
| 450 BL | 20 |
| 500 BL | 20 |
| 550 BL | 20 |
| 600 BL | 20 |

| Medida | U/E |
|--------|-----|
| 300 MA | 20 |
| 350 MA | 20 |
| 400 MA | 20 |
| 450 MA | 20 |
| 500 MA | 20 |
| 550 MA | 20 |
| 600 MA | 20 |

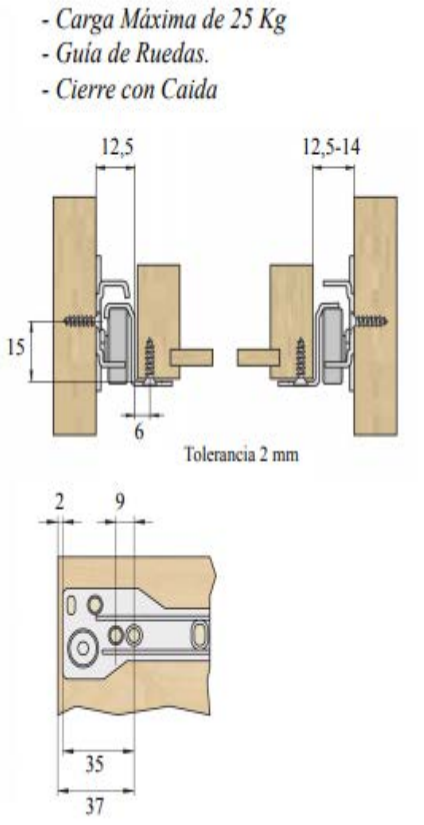

Plano

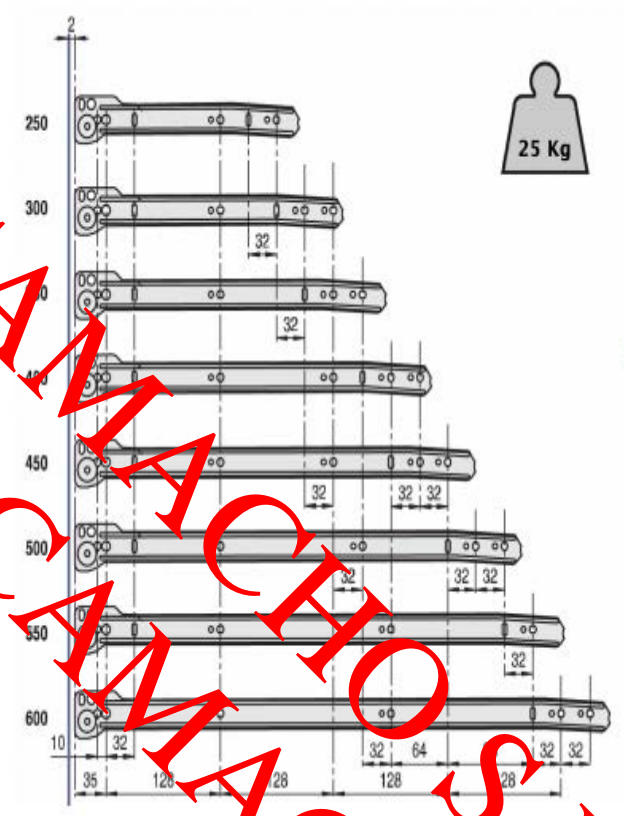

WWW.MADERASCAMACHO.S.L